

CORRECTION

Open Access



Correction: Active Compliance Control of a Position-Controlled Industrial Robot for Simulating Space Operations

Jun He^{1*}, Mingjin Shen¹, Feng Gao¹ and Haibo Zhang²

Correction: Chinese Journal of Mechanical Engineering (2022) 35:149
<https://doi.org/10.1186/s10033-022-00821-1>

In the original publication of this article [1], the figure 2b is incorrect, the correct figure 2b is as below. The original publication has been corrected.

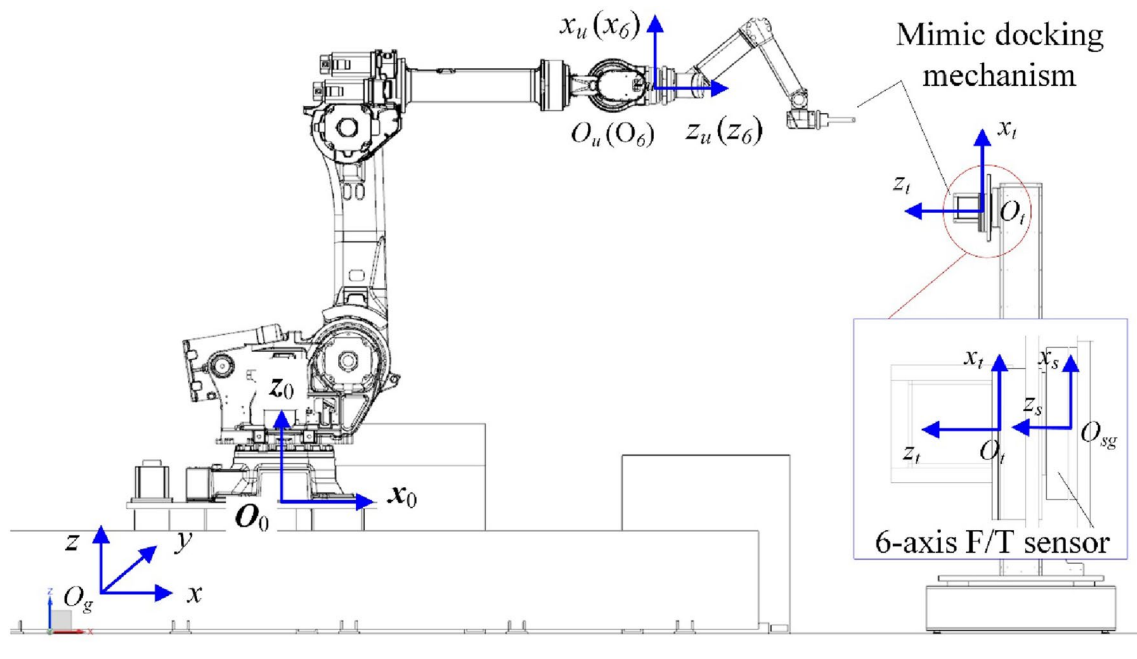

The original article can be found online at <https://doi.org/10.1186/s10033-022-00821-1>.

*Correspondence:

Jun He

jhe@sjtu.edu.cn

¹ State Key Laboratory of Mechanical System and Vibration, School of Mechanical Engineering, Shanghai Jiao Tong University, Shanghai 200240, China

² Beijing Institute of Control Engineering, Beijing 100190, China

Published online: 02 February 2023

Reference

- [1] J He, M Shen, F Gao, H Zhang. *Chinese Journal of Mechanical Engineering* (2022) 35:149 <https://doi.org/10.1186/s10033-022-00821-1>



© The Author(s) 2023. **Open Access** This article is licensed under a Creative Commons Attribution 4.0 International License, which permits use, sharing, adaptation, distribution and reproduction in any medium or format, as long as you give appropriate credit to the original author(s) and the source, provide a link to the Creative Commons licence, and indicate if changes were made. The images or other third party material in this article are included in the article's Creative Commons licence, unless indicated otherwise in a credit line to the material. If material is not included in the article's Creative Commons licence and your intended use is not permitted by statutory regulation or exceeds the permitted use, you will need to obtain permission directly from the copyright holder. To view a copy of this licence, visit <http://creativecommons.org/licenses/by/4.0/>.